

ALUMINIUM ORDER PICKING PLATFORM

The new Bailey Order Picking Platforms are packed with features making working at heights safer, easier and more efficient. The Bailey Order Picking Platforms make stock picking a breeze.



Safety gate included as standard



Large platform for extra comfort



Rear tilt castor included. Choose to fit or not



Large 100mm castor repositioned for stability

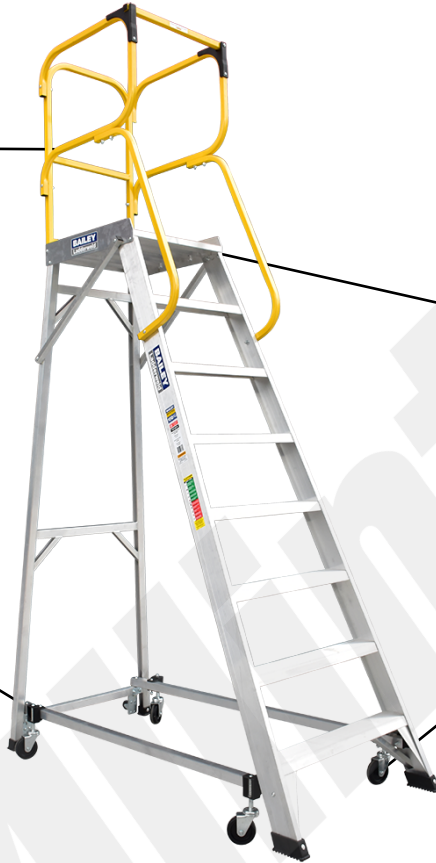

KEY FEATURES

Industrial Duty Rated order picking ladder
Designed for use on commercial sites and warehouses

Light and strong aluminium construction
With heavy duty tread and stiles

Safety gate included as standard

Rear Tilt-N-Go castors

Large 600 x 500mm platform

Box section back legs
Provide greater strength and rigidity

Ideal for:
Stock picking or industrial applications

Spring loaded castors
For ease of manoeuvrability

Supplied flat packed
With the tools required for assembly

Made to Australian Standards AS1892

SPECIFICATIONS

INDUSTRIAL 150KG

STOCK CODE	MODEL NO	TYPE	PLATFORM HEIGHT (M)	FULLY OPEN (W X D) (MM)	WEIGHT (KG)
AR00323	FS13876	5 Step Order Picking Platform	1.38	731 X 1302	25.9
AR00324	FS13877	6 Step Order Picking Platform	1.65	711 X 1443	28.5
AR00326	FS13879	8 Step Order Picking Platform	2.2	1726 X 1726	32.7

Distributed By:



Email: sales@allinton.com.sg
www.allinton.com.sg

HEAD OFFICE
331 JALAN BESAR, SINGAPORE 208983
TEL: (65) 6296 0679
FAX: (65) 6297 0024

BRANCH OFFICE
21 TUAS BASIN LINK, SINGAPORE 638782
TEL: (65) 6265 1888
FAX: (65) 6265 5623

ORDER PICKING PLATFORM RANGE/ INDUSTRIAL 150KG

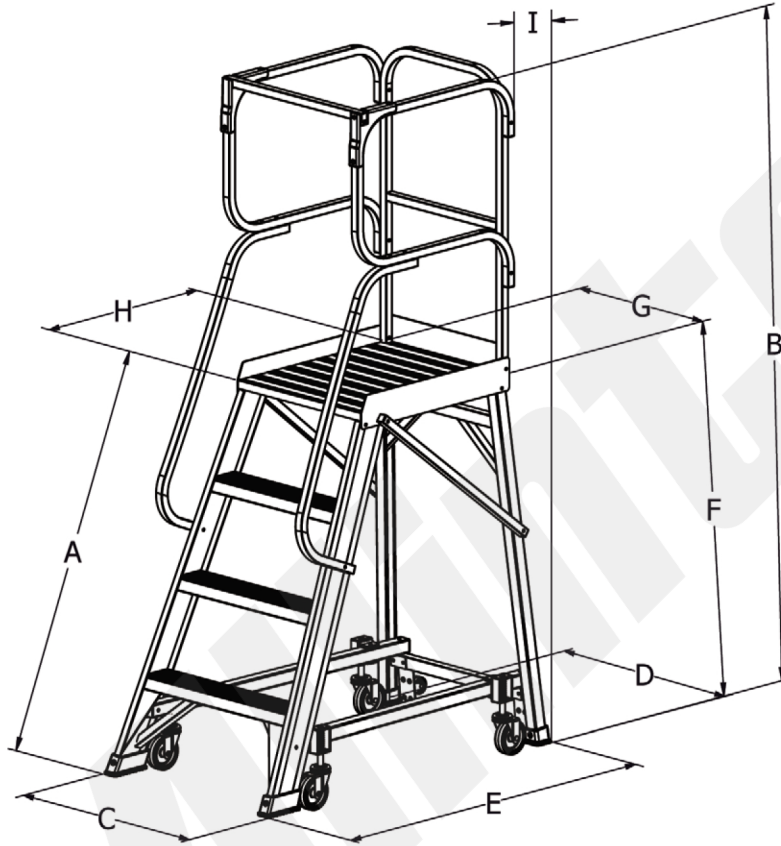

PRODUCT CODE	PRODUCT DESCRIPTION	PRODUCT EAN	A(mm)	B(mm)	C(mm)	D(mm)	E(mm)	F(mm)
FS13873	AL ORDER PICKING PLATFORM 2 MK3 150KG IND	9312097063112	597	1460	595	610	878	552
FS13874	AL ORDER PICKING PLATFORM 3 MK3 150KG IND	9312097063129	898	1736	636	651	1019	828
FS13875	AL ORDER PICKING PLATFORM 4 MK3 150KG IND	9312097063136	1198	2012	676	691	1161	1104
FS13876	AL ORDER PICKING PLATFORM 5 MK3 150KG IND	9312097063143	1498	2289	716	731	1302	1381
FS13877	AL ORDER PICKING PLATFORM 6 MK3 150KG IND	9312097063150	1798	2564	756	771	1443	1656
FS13878	AL ORDER PICKING PLATFORM 7 MK3 150KG IND	9312097063167	2098	2841	796	811	1585	1933
FS13879	AL ORDER PICKING PLATFORM 8 MK3 150KG IND	9312097063174	2397	3116	835	1726	1726	2208
PRODUCT CODE	PRODUCT DESCRIPTION	PRODUCT EAN	G(mm)	H(mm)	I(mm)	WT(kg)	PACKED VOL. (M ³)	
FS13873	AL ORDER PICKING PLATFORM 2 MK3 150KG IND	9312097063112	500	600	46	20.0	0.178	
FS13874	AL ORDER PICKING PLATFORM 3 MK3 150KG IND	9312097063129	500	600	71	22.1	0.220	
FS13875	AL ORDER PICKING PLATFORM 4 MK3 150KG IND	9312097063136	500	600	95	24.0	0.260	
FS13876	AL ORDER PICKING PLATFORM 5 MK3 150KG IND	9312097063143	500	600	119	25.9	0.325	
FS13877	AL ORDER PICKING PLATFORM 6 MK3 150KG IND	9312097063150	500	600	143	28.5	0.395	
FS13878	AL ORDER PICKING PLATFORM 7 MK3 150KG IND	9312097063167	500	600	167	30.5	0.473	
FS13879	AL ORDER PICKING PLATFORM 8 MK3 150KG IND	9312097063174	500	600	835	32.7	0.552	

Distributed By:



Email: sales@allinton.com.sg
www.allinton.com.sg

HEAD OFFICE
331 JALAN BESAR, SINGAPORE 208983
TEL: (65) 6296 0679
FAX: (65) 6297 0024

BRANCH OFFICE
21 TUAS BASIN LINK, SINGAPORE 638782
TEL: (65) 6265 1888
FAX: (65) 6265 5623